

High Productivity Cooking Steam Tilting Boiling Pan, 300lt Freestanding, Manual

ITEM # _____

MODEL # _____

NAME # _____

SIS # _____

AIA # _____

586073 (PBOT30THCO)

 Steam tilting Boiling Pan
 300lt (s) with manual steam
 control, freestanding

Short Form Specification

Item No.

AISI 304 stainless steel construction. Deep drawn vessel in AISI 316 stainless steel. Insulated and counterbalanced lid. Motorized tilting with variable speed control. Pan can be tilted beyond 90° to completely empty the food. Food is uniformly heated via the base and the side walls of the pan by an indirect heating system using integrally generated saturated steam at a maximum temperature of 125°C in a jacket with an automatic deaeration system. Safety valve avoids overpressure of the steam in the jacket. Safety thermostat protects against low water level in the double jacket. Possibility to store recipes in single or multiphase cooking process, with different temperature settings. Built in temperature sensors for precise control of cooking process. IPX6 water resistant. Configuration: Free-standing or Standing against a wall. Installation options (not included): floor mounted on 100mm high feet or a plinth which can be either steel or masonry construction.

Main Features

- Kettle is suitable to boil, steam, poach, braise or simmer all kinds of produce.
- Produce is uniformly heated in the vessel by an indirect heating system using saturated steam.
- Isolated upper well rim avoids risk of harm for the user.
- Max pressure of inner jacket at 1,5 bar; minimum working pressure at 0.5 bar.
- Self-contained steam-source: a booster feeds steam directly into the double jacket.
- Ergonomic vessel dimensions, with a large diameter and shallow depth facilitates stirring and gentle food handling.
- Edge of the large pouring lip can be equipped with a strainer (option).
- Motorized, variable pan tilting with "SOFT STOP". Tilting and pouring speeds can be precisely adjusted. Pan can be tilted over 90° to facilitate pouring and cleaning operations.
- IPX6 water resistant.

Construction

- Cooking vessel in 1.4435 (AISI 316L) stainless steel featuring directional pouring lip. Double-jacket in 1.4404 (AISI 316L) stainless steel designed to operate at a pressure of 1.5 bar.
- External panelling and internal frame made of 1.4301 (AISI 304) stainless steel.
- Double-lined insulated lid in 1.4301 (AISI 304) stainless steel mounted on the cross beam of the unit, counterbalanced by a hinge that remains open in all positions.
- Safety valve avoids overpressure of the steam in the double jacket.
- External steam feeding; 1,5 bars working pressure.
- Safety thermostat protects against low water level in the double jacket.
- Water mixing tap is available as optional accessory to make water filling and pan cleaning easier.
- Ergonomic and user friendly thanks to the high tilting position and the pouring lip design which allow to easily fill containers.
- Minimised presence of narrow gaps for easier cleaning of the sides to meet the highest hygiene standards.
- Can be prearranged for energy optimisation or external surveillance systems (optional).
- 98% recyclable by weight; packaging material free of toxic substances.

User Interface & Data Management

APPROVAL: _____

- Connectivity ready for real time access to connected appliances from remote and data monitoring (requires optional accessory - contact the Company for more details).

Optional Accessories

- | | | | | | |
|--|------------|--------------------------|---|------------|--------------------------|
| • Bottom plate with 2 feet, 100mm for tilting units (height 800mm) - factory fitted | PNC 911478 | <input type="checkbox"/> | • Lower rear backpanel for tilting units with or without backsplash - factory fitted | PNC 912771 | <input type="checkbox"/> |
| • Stainless steel plinth for tilting units - against wall - factory fitted | PNC 911623 | <input type="checkbox"/> | • Spray gun for tilting units - freestanding (height 800mm) - factory fitted | PNC 912777 | <input type="checkbox"/> |
| • Stainless steel plinth for tilting units - freestanding - factory fitted | PNC 911624 | <input type="checkbox"/> | • Food tap 2" for tilting boiling pans (PBOT) - factory fitted | PNC 912779 | <input type="checkbox"/> |
| • C-board (length 1500mm) for tilting units - factory fitted | PNC 912187 | <input type="checkbox"/> | • Emergency stop button - factory fitted | PNC 912784 | <input type="checkbox"/> |
| • Power Socket, CEE16, built-in, 16A/400V, IP67, red-white - factory fitted | PNC 912468 | <input type="checkbox"/> | • Mixing tap with drip stop, two knobs, 815mm height, 600mm swivelling depth for PBOT/PFET - factory fitted | PNC 913554 | <input type="checkbox"/> |
| • Power Socket, CEE32, built-in, 32A/400V, IP67, red-white - factory fitted | PNC 912469 | <input type="checkbox"/> | • Mixing tap with drip stop, two knobs, 815mm height, 450mm swivelling depth for PBOT/PFET - factory fitted | PNC 913555 | <input type="checkbox"/> |
| • Power Socket, SCHUKO, built-in, 16A/230V, IP68, blue-white - factory fitted | PNC 912470 | <input type="checkbox"/> | • Mixing tap with drip stop, two knobs, 685mm height, 600mm swivelling depth for PBOT/PFET - factory fitted | PNC 913556 | <input type="checkbox"/> |
| • Power Socket, TYP23, built-in, 16A/230V, IP55, black - factory fitted | PNC 912471 | <input type="checkbox"/> | • Mixing tap with drip stop, two knobs, 685mm height, 450mm swivelling depth for PBOT/PFET - factory fitted | PNC 913557 | <input type="checkbox"/> |
| • Power Socket, TYP25, built-in, 16A/400V, IP55, black - factory fitted | PNC 912472 | <input type="checkbox"/> | • Mixing tap with two knobs, 520mm height, 600mm swivelling depth for PXXT- KWC - factory fitted | PNC 913567 | <input type="checkbox"/> |
| • Power Socket, SCHUKO, built-in, 16A/230V, IP55, black - factory fitted | PNC 912473 | <input type="checkbox"/> | • Mixing tap with one lever, 564mm height, 450mm swivelling depth for PXXT- KWC - factory fitted | PNC 913568 | <input type="checkbox"/> |
| • Power Socket, CEE16, built-in, 16A/230V, IP67, blue-white - factory fitted | PNC 912474 | <input type="checkbox"/> | | | |
| • Power Socket, TYP23, built-in, 16A/230V, IP54, blue - factory fitted | PNC 912475 | <input type="checkbox"/> | | | |
| • Power Socket, SCHUKO, built-in, 16A/230V, IP54, blue - factory fitted | PNC 912476 | <input type="checkbox"/> | | | |
| • Power Socket, TYP25, built-in, 16A/400V, IP54, red-white - factory fitted | PNC 912477 | <input type="checkbox"/> | | | |
| • Panelling for plinth recess (depth from 70 to 270mm) for tilting units - factory fitted (Deutschland, Austria, Switzerland) - factory fitted | PNC 912479 | <input type="checkbox"/> | | | |
| • Manometer for tilting boiling pans - factory fitted | PNC 912490 | <input type="checkbox"/> | | | |
| • Kit energy optimization and potential free contact - factory fitted | PNC 912737 | <input type="checkbox"/> | | | |
| • Rear closing kit for tilting units - against wall - factory fitted | PNC 912753 | <input type="checkbox"/> | | | |
| • Rear closing kit for tilting units - island type - factory fitted | PNC 912759 | <input type="checkbox"/> | | | |

Front

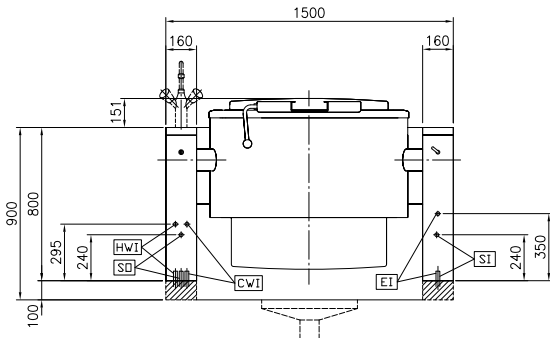

Side

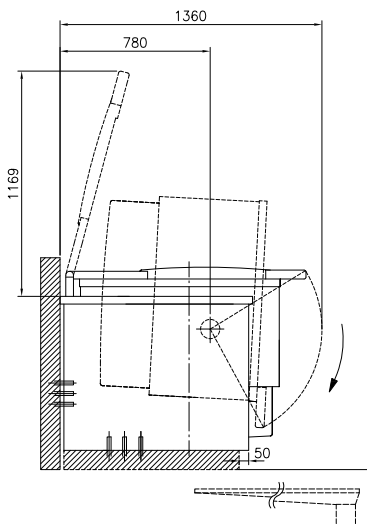

- CWI1 = Cold Water inlet 1 (cleaning)
 EI = Electrical inlet (power)
 HWI = Hot water inlet
 SI = Steam inlet
 SO = Steam outlet

Top

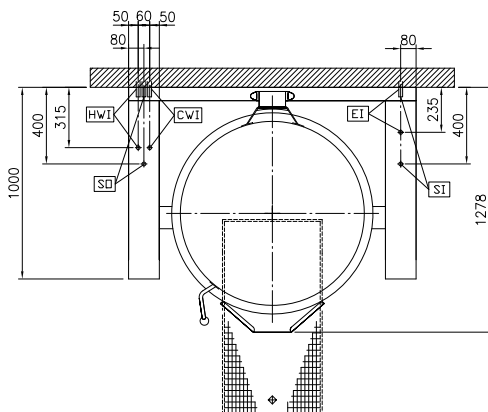

Electric

Supply voltage:	230 V/1N ph/50/60 Hz
Total Watts:	0.2 kW

Steam

Steam generation:	External source
Steam inlet size:	1"
Steam pressure Max:	1.5 bar
Steam supply, relative dynamic pressure:	1 min bar, 1.5 max bar

Water:

Pressure, min-max:	2-6 bar
--------------------	---------

Installation:

FS on concrete base; FS on feet; On base; Standing against wall

Type of installation:

Key Information:

Working Temperature MIN:	50 °C
Working Temperature MAX:	110 °C
Vessel (round) diameter:	900 mm
Vessel (round) depth:	570 mm
External dimensions, Width:	1500 mm
External dimensions, Depth:	1000 mm
External dimensions, Height:	800 mm
Net weight:	390 kg
Configuration:	Round; Tilting
Net vessel useful capacity:	300 lt
Tilting mechanism:	Automatic
Double jacketed lid:	✓
Heating type:	Indirect

Sustainability

Steam consumption:	105 kg/hr
--------------------	-----------